



# 产品承认书 SPECIFICATION FOR APPROVAL

客户名称:

CUSTOMER

我司料号:

OUR PART NO.

XR0514-104

我司品名:

OUR PART NAME

Color ring inductance

送样日期:

DATE SAMPLES

数量:

QUANTITY

## 制造确认 MANUFACTURER APPROVE

拟制 DRAWN	审核 CHECKED	确认 APPROVED
HuFangting	RaoPin	Zhongcuilan

## 客户确认 CUSTOMER APPROVE

客户名称 CUSTOMER NAME:

客户料号 CUSTOMER P/N:

规格型号 DESCRIPTION: 0514 100mH ±10% 5mA

检查结果:  合格  不合格

签名及盖章:

INSPECT RESULT ACCEPT REJECT

SIGNATURE AND STAMP

说明 REMARK:

如对本承认书内容有异议请提出或标记发送至我司，本承认书在未收到异议回复时于本承认书提供一周后生效。

If you have any objection to the contents of this acknowledgement, please put forward or mark it and send it to our company.

This acknowledgement will take effect one week after it is provided if you do not receive an objection reply.

东莞市祥如电子有限公司

Dongguan xiangru electronics co., ltd

Tel: 0769-86346548 Fax: 0769-86346358

email: dgxiangru@126.com



# 产品承认书

## SPECIFICATION FOR APPROVAL

客户名称 CUSTOMER		日期 DATE	2024/5/29
客户物料编号 CUSTOMER P/N		客户规格型号 DESCRIPTION	0514 100mH ±10% 5mA
我司物料编号 OUR PART NO	XR0514-104	我司品名 OUR PART NAME	Color ring inductance

**外观尺寸 Appearance of size**

单位 Unit: mm

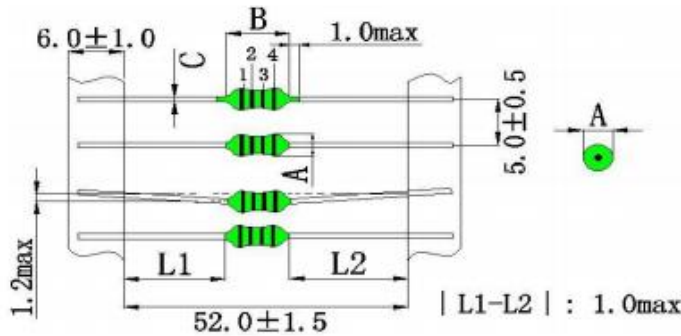

A	5.0 MAX	B	15.0 MAX	C	0.6±0.1		
标识Identification		依据具体规格号 According to the specific specification number					

**原理图 Schematic Diagram:**

**注意事项 Matters needing attention:**

1、由于油漆调配比例略有差异，烘烤时间及烘烤温度存有差异，不同批次或同一批次存有色差属正常现象。 Due to the slight difference in paint blending ratio, there are differences in baking time and baking temperature, and it is normal for different batches or the same batch to have color difference:

2、不要使产品遭受温度和湿度的快速变化，易造成电感涂层开裂，建议使用温度范：-20~+125℃； Don't subject the product to rapid changes in temperature and humidity, which may easily lead to cracking of the inductor coating. It is recommended to use the temperature norm of -20 ~+125℃;

3、色环电感成品外观检查事项及标准详见以下附件： See the following attachments for the appearance inspection items and standards of finished products of color ring inductors:



产品承认书  
SPECIFICATION FOR APPROVAL

客户名称 CUSTOMER		日期 DATE	2024/5/29
客户物料编号 CUSTOMER P/N		客户规格型号 DESCRIPTION	0514 100mH ±10% 5mA
我司物料编号 OUR PART NO	XR0514-104	我司品名 OUR PART NAME	Color ring inductance

电性参数  
Electrical parameters

品名规格Commodity specification	XR0514-104K	磁芯规格Magnetic core specification	DRWW4 8		
漆包线enamelled wire	2UEWØ0.04mm	合数composite number	2420 TS	色环标识Color ring identification	1.棕色 2.黑色 3.黄色 4.银色 1. Brown 2. Black 3. Yellow 4. Silver
测试项目 TEST PROJECT	电性范 SPEC	测试条件 TEST FREQ	测试仪器 TEST STRUMENTS		
电感量L	100mH±10%	at 25°C 1KHz/0.25V	TH2829A		
直流电阻DCR	420 MAX	at 25°C 1KHz/0.25V	TH2829A		
饱和电流Isat	L ≥ L0 90%	at 25°C DC5mA 1KHz/1V	TH2829A		

物料清单 BOM

物料 MATERIAL	规格型号 SPECIFICATIONS	制造厂商 MANUFACTURERS	UL证书号 UL FILE NO
CORE	Ferrite core DRWW4*8	JIACHENG	
		OR Equivalent supplier	
WIRE	2UEW-F(QA)	CHENGWE	E227475
		OR Equivalent supplier	
PIN	Tinned copper clad steel wire (CP)	BAICHUAN	
		OR Equivalent supplier	
EPOXY PAINT	DGT-1(green)	QIFU	
		OR Equivalent supplier	
EPOXY RESIN	DZ-6	JINGDINGSHENG	
		OR Equivalent supplier	
SOLDER	Sn:99.3%/Cu:0.7%	SONGBEN	
		OR Equivalent supplier	

## 注意事项 Matters needing attention

1、本承认书保证我司产品作为一个单体时的质量情况，当我司产品被安装到贵司产品上时，请保证我司的产品已根据贵司的规范进行了有效评价和确认。

Specification for approval that guarantee the quality of our products as a monomer, when our products were installed on your products, please make sure that our products are according to your specification for the effective evaluation and confirmation.

2、本承认书的更改需经双方确认，任何一方单独修改无效。

The recognition of the need to change the book recognized by both parties, either party to amend a separate as null and void.

3、本承认书在客户收到的七个工作日内，必须签章返回，逾期视为默认。

Admit in the book the customer received within seven working days, must return signature, late regarded as the default.

4、该电感器磁芯的中部缠绕有漆包线并连接于两端引脚，引脚成型过程中可能造成开路或损伤本体。当您执行引脚成型过程时，请遵守以下指示：

The middle part of the core of the inductor is wound with enameled wires and is connected with the pins at both ends, Pin forming process may cause open circuit or damage the body. When you perform the pin forming process, Please comply with the following instruction: Please apply supporting jigs as below

包装说明及示意图 Packing instructions and schematic diagram:

