



# 产品承认书 SPECIFICATION FOR APPROVAL

客户名称:

CUSTOMER

我司料号:

OUR PART NO.

ES92717HQ

我司品名:

OUR PART NAME

Lan Transformer

送样日期:

DATE SAMPLES

数量:

QUANTITY

## 制造确认 MANUFACTURER APPROVE

拟制 DRAWN	审核 CHECKED	确认 APPROVED
ZhaoYinyin	RaoPing	ZhongCuilan

## 客户确认 CUSTOMER APPROVE

客户名称 CUSTOMER NAME:

客户料号 CUSTOMER P/N:

规格型号 DESCRIPTION:

ES92717HQ

检查结果:  合格  不合格

INSPECT RESULT ACCEPT REJECT

签名及盖章:

SIGNATURE AND STAMP

说明 REMARK:

如对本承认书内容有异议请提出或标记发送至我司, 本承认书在未收到异议回复时于本承认书提供一周后生效。

If you have any objection to the contents of this acknowledgment, please raise it or send the mark to us. The acknowledgment will become effective one week after the acknowledgment is provided in the absence of any objection.

东莞市祥如电子有限公司

DONGGUAN XIANGRU ELECTRONICS CO., LTD

Tel: 0769-86346548 Fax: 0769-86346358

Email: dgxiangru@126.com

## 产品承认书

### SPECIFICATION FOR APPROVAL

客户名称 CUSTOMER		日期 DATE	2025/05/20
客户物料编号 CUSTOMER P/N		客户规格型号 DESCRIPTION	ES92717HQ
我司物料编号 OUR PART NO	ES92717HQ	我司品名 OUR PART NAME	Lan Transformer

**Parameter table (特性参数):**

Part No	OCL(uH min) @100KHz/0.1Vrms, 8mA	Turns Ratio(3%)	DCR (Ω) Max	Cww(Pri:Sec) pF Typ	Isolation Voltage(AC Vrms 3S)		
ES92717HQ	350uH	1:1	0.9/1.2	35	1500V		
Part No	Insertion loss(dB max) 1-100MHz	Return Loss(dB Min) MHz			CMRR(dB min)MHz		Crosstalk(dB min)MHz
		1-30	40-60	60-100	1-60	60-100	
ES92717HQ	-1.2	-18	-16	-14	-40	-30	-35

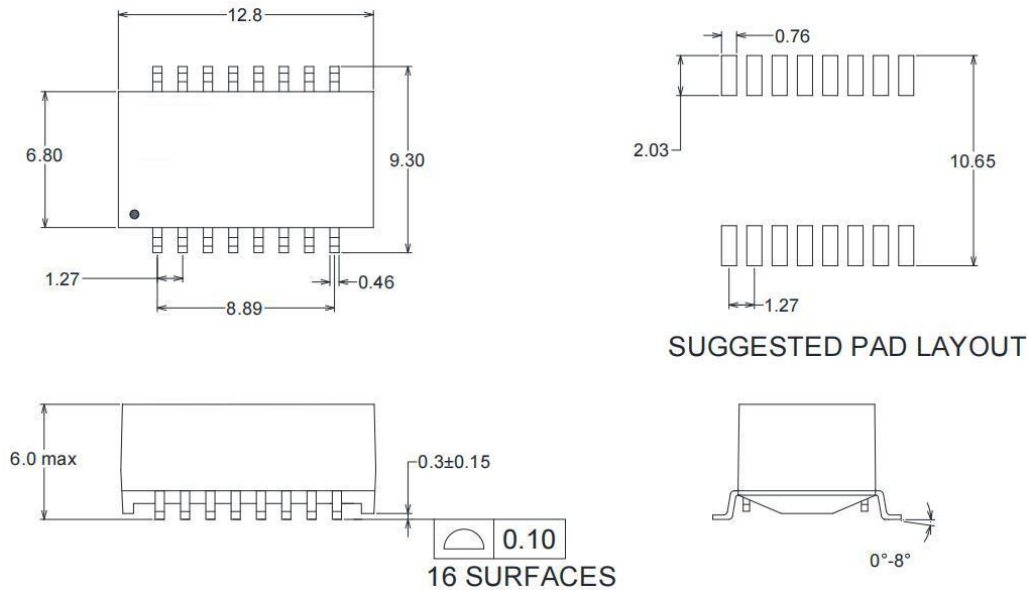
**MECHANICAL (外观尺寸图):**

**1特点Features:**

- 1.1: 符合IEEE802\_3和ANSIX3.263标准和RoHS标准。Meets IEEE 802.3 and ANSIX3.263 standards .RoHS Compliant
- 1.2: 10/100Base-T, 表面贴装类型, 开放式头电缆接口。10/100Base-T, Surface Mount Type, Open Header
- 1.3: 工作温度范围:0℃至+70℃。Operating temperature range: 0℃ to +70℃
- 1.4: 存储温度范围:-40℃至+85℃。Storage temperature range: -40℃ to +85℃
- 1.5: 用于隔离和低共模发射。Cable interface for isolation and low common mode emissions.
- 1.6: 回流焊接温度:峰值温度<250° C(10s)。Reflow soldering temperature: peak temperature ≤ 250 °C (10s)
- 1.7: 回流焊接频率:建议不超过3次。Reflow soldering frequency: It is recommended not to exceed 3 time

# 产品承认书

## SPECIFICATION FOR APPROVAL

客户名称 CUSTOMER		日期 DATE	2025/05/20
客户物料编号 CUSTOMER P/N		客户规格型号 DESCRIPTION	ES92717HQ
我司物料编号 OUR PART NO	ES92717HQ	我司品名 OUR PART NAME	Lan Transformer

### SCHEMATICS (原理图) :

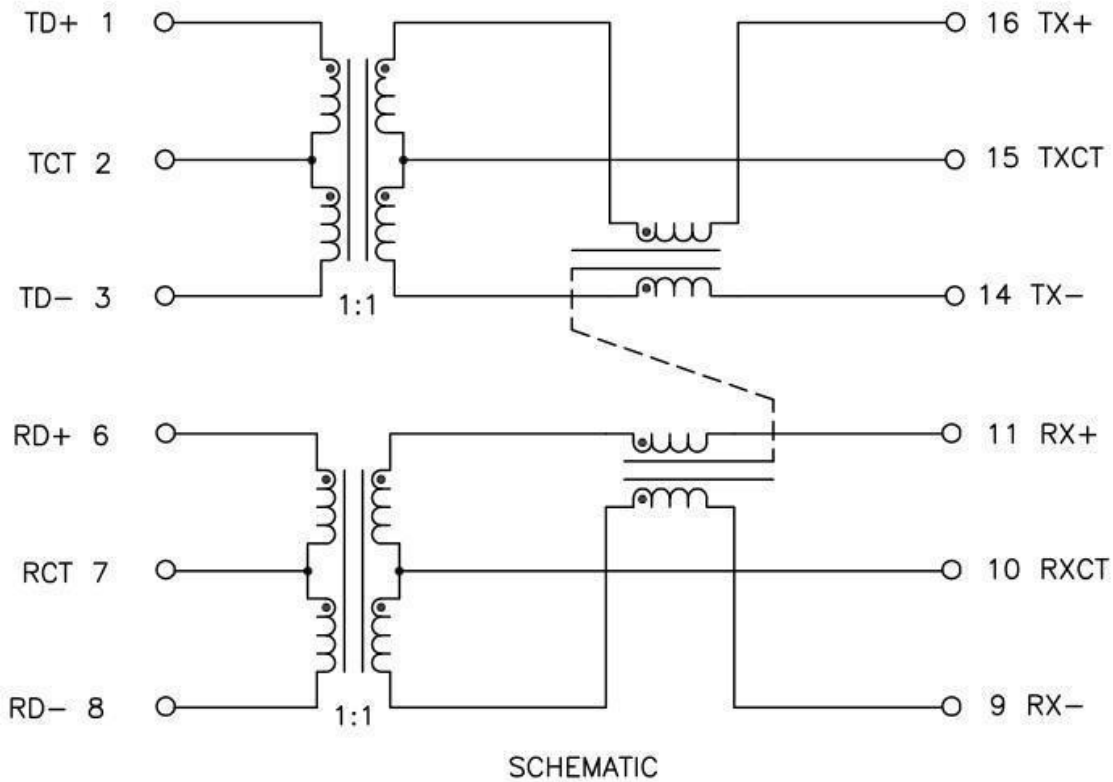

### Packaging information:

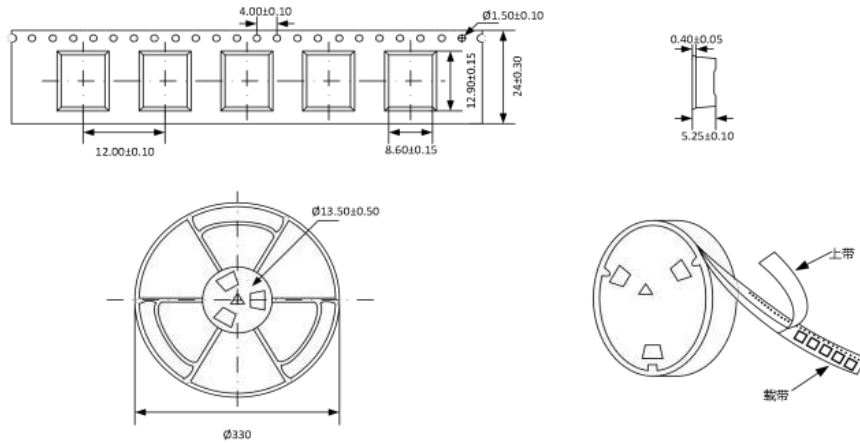

※ Unit: mm

※ Packaging quantity (MOQ): \* pcs/roll \* pcs/box